

**RELATIONSHIP BETWEEN SCHOOL ADMINISTRATORS' USAGE OF  
GRAPEVINE COMMUNICATION AND TEACHERS' JOB PERFORMANCE IN  
UNITY SCHOOLS IN SOUTH-SOUTH, NIGERIA**

By

**OTONKUE, Raymond Emmanuel, Ph.D.  
Institute of Education  
University of Calabar, Calabar**

And

**Ikwen, Amokeye Banbeshie.  
University of Calabar, Calabar.**

**ABSTRACT**

*The study was carried out to assess the relationship between school administrators' usage of grapevine communication and teachers' job performance in unity schools in South-South, Nigeria. A correlational design was adopted for the study. The research area was South-South Nigeria. The population of this study was 1,644 respondents which comprised all the 17 principals and 1,627 teachers of all the seventeen (17) unity schools of 2020/2021 academic session in South-South education zone, Nigeria. Simple random sampling technique was used to select a total of was 510 respondents which comprises of 50 teachers from the 10 selected unity secondary schools and 10 principals from each of the 10 selected unity secondary schools. The instruments for data collection were 'School Communication of Administrators Questionnaire (SCAQ) and 'Teacher Job Performance Questionnaire (TJPQ). The data obtained were analysed using Pearson Moment Correlation Coefficient. Linear Regression analysis (ANOVA) was used to test the null hypotheses at 0.05 level of significance. Conclusions made from the study states that on the overall that school administrators' communication; (grapevine communication) to a high extent relate to teachers' Job performance in unity secondary schools. This implies that This implies that effective management and use of grapevine communication by school administrators. One of the recommendations made from the study was that School administrators should properly manage grapevine communication in the school by providing accurate and timely information to teachers so as to reduce rumors and misinformation*

**KEYWORDS: Unity Schools, Grapevine communication, Job Performance**

---

**INTRODUCTION**

Grapevine communication occurs outside formal channels and is driven largely by personal relationships and social networks among employee. It is prevalent in organizations of all sizes and types and serves as a key means through which information, ideas, and opinions are shared rapidly among staff. Grapevine communication can carry both accurate and distorted messages, and it often reflects the sentiments, anxieties, and perceptions of organizational members (Kumar, 2012).

In general, informal communication networks like the grapevine are essential to understanding workplace dynamics. According to Greenberg and Baron (2018), grapevine communication can promote teamwork, improve social bonds, and enhance collaboration among employees. It functions as a complementary channel to formal communication, filling

gaps in information flow and providing employees with a sense of inclusion and emotional relief. The grapevine also acts as a barometer of employee morale, revealing hidden concerns, rumors, and attitudes that might not emerge through official channels.

The grapevine is characterized by its speed, flexibility, and reach. Messages spread through this network more quickly than through formal channels and can cross hierarchical boundaries without restriction (Lussier, 2018). Structural patterns of grapevine communication include single-strand chains, gossip chains, probability chains, and cluster chains, each serving a unique role in the dissemination of information (Pravin, 2013). Participation in the grapevine varies, with some employees acting as key communicators, while others are passive or isolated from the network (Kumar, 2013).

While grapevine communication offers several advantages, such as fostering social cohesion and providing timely information, it also presents challenges, including rumor propagation, misinformation, and distortion of facts (Tehaeureka, 2012). The effectiveness of this communication channel depends on organizational climate, employee trust, and management's ability to engage with and guide the informal network (Sapre, 2011). Properly managed, grapevine communication can enhance workplace efficiency, morale, and decision-making, making it an indispensable element of organizational life.

### **Statement of Problem**

Unity schools' teachers are personnel trained in knowledge, skills, attitude and values, in formal training institutions, to teach or impart same to the learners in the most acceptable way. It originates from the psychological need of employees to discuss their work, colleagues, and organizational events. While grapevine communication can help fill information gaps and provide rapid feedback to management, it can also spread unverified messages, distort facts, and sometimes create misunderstanding among employees (Kumar, 2012; Lussier, 2018).

The issue of grapevine communication and its influence on employee behavior and organizational outcomes has been a long-standing concern for managers. In educational institutions and other workplaces, unchecked grapevine networks have been linked to rumors, misinformation, and negative sentiments, which can affect teamwork, morale, and productivity. Employees may act on distorted information, make premature decisions, or develop mistrust toward management, leading to inefficiency and conflict.

Despite the potential benefits of informal communication, such as rapid transmission of information, social bonding, and emotional relief, the negative consequences often outweigh the positives when the communication is not monitored or guided (Sapre, 2011). Managers frequently struggle to control the grapevine, and employees may exploit it for personal interests, spreading false or exaggerated information that disrupts the organization.

In view of this, the study deemed it pertinent to raise a query which it seeks to answer: To what extent does grapevine communication influence employee behavior, productivity, and overall organizational effectiveness in institutions?

### **Objective of the Study**

The study sought to:

1. To find out the extent to which school administrators' usage of grapevine communication relate teachers' job performance in unity schools.

### **Research Question**

1. To what extent does school administrators' grapevine communication relate with teachers' job performance in unity schools?

### **Hypotheses**

1. There is no significant relationship between school administrators' grapevine communication and teachers' job performance in unity schools.

## **LITERATURE REVIEW**

### **The Concept of Communication**

Communication process is a very important aspect of school organization. The concept of communication in formal organization has received consideration attention in recent years. Education is one of the organizations whose functions depend on effective communication and coordination in the educational management, interactions and between the teachers and principals (Ibiam, 2015). Educational administrators spend ample time communicating. As a result, the critical role communication plays in school and the effort devoted to it means that effective communication skill is an essential process in school life. This means that school administrator should understand communication because it permeates the instructional, interpersonal and administrative processes of schools. Consequently, for school administrators to boost the job effectiveness of their teachers, they must be versed in the acquisition and utilization of effective communication.

Wentz (2018) stated that effective communication involves more than speaking. People communicate by writing, listening, and using non-verbal signals to get their message across. What people do not say while speaking could be just as important as what they do say, and how our body language supports or refutes what we are saying could mean the difference between communicating and just speaking. School administrators, according to Laud (2018), spend the vast majority of their days communicating. How they address their faculties can set the stage for effective communications and excellent teachers' performance within a school.

### **Principals' grapevine communication**

Grapevine communication skill, often referred to as informal communication, is based predominantly on cordial interactions among members in the network (Bratton, et al, 2017). A weak and ineffective formal organizational communication may be the consequence of this outcome. However, the informal communication network without official verification is not necessarily bad. The existence of a parallel and strong information communication may be a challenge to the formal structure. This is especially so when there is rampant and uncorroborated rumors in the network. Information on that network can be used to formulate effective communication policies for the organization. According to Sostek (2016), informal communication networks can be the source of rumors, and can be good or bad depending on the content. Rumors about individuals are bad since the objective is mostly to hurt them. However, when it's about the achievement of other groups within the organization, it releases creative energy and spur productivity within groups. For this reason, management may tolerate some rumors on the informal network (Sostek, 2016). Studies have also revealed that, informal socialization between employees can improve productivity and teamwork in the organization (Greenberg & Baron, 2018).

Reviewing various studies done by Bratton et al, (2017), grapevine or rumor tested to be one of the fastest channels and often accurate. Distortions arise when people repackage the information they received to suit their narratives and expectations. This may to exaggerations, and distortions and omissions (Tubbs & Moss, 2018). For this reason, information from the informal channel is considered second class by employees. To avoid the challenges associated with grapevine communication, empirical studies have suggested some alternatives that organizations can use. This includes individual chats bringing up discussions with employees about social activities, organizational meetings, and meetings with middle managers (Tubbs & Moss, 2018). Informal communication networks are invariably based on the off-the-record acquaintances between staff and (Greenberg & Baron, 2018). People tend to gravitate towards others who share their features and characteristics. By communicating with others like themselves, employees share a lot of useful and valuable information. By sharing similar backgrounds, people can relate and empathize with each other.

Prior studies found that a strong informal communication have a positive impact on employees' productivity (Greenberg & Baron, 2018). A strong informal communication networks encourages face-face meetings where information is regularly shared. This can be rewards or awards in different groups, job prospects or even incentives for performance, and where they can be found in the organization. According to Prakashv (2019), the grapevine is a type of internal informal communication network which is not actually sanctioned by the organization. It links employees from in direction ranging from higher authorities to least workers. It always exist in an organization and it becomes most when all the formal channels are closed. The discussions can be anything about the organization or personal. Mostly grapevine communication develops rumors about the firm and to less extend about personal. It is estimated that more than half percentage of communication in an organization is carried through this.

Most of the messages passed through the grapevine are accurate. In a survey of 22,000 shift workers in varied industries of the United States of America, 55% said that they got most of their information via the grapevine. Smart managers understand the company's grapevine. They recognize who's connected to whom and which employees are key players in the informal spread of communication. Information transmitted through the grapevine tends to undocumented and thereby susceptible to variation and interpretation. Organizational grapevine probably should not be taken too seriously. It involves not only the current employees, but also the former employees and total strangers. An overabundance of grapevine rumors undoubtedly can be as a sign of organizational dysfunction, reflecting the loss of confidence in company's hierarchy, excessive secrecy and fear, and political problems in the company. In all cases, but particularly in time of crisis, executives need to manage communication effectively so that the grapevine is not the only source of communication.

Pravin (2013) identified four major structural flows of a grapevine communication. These are:

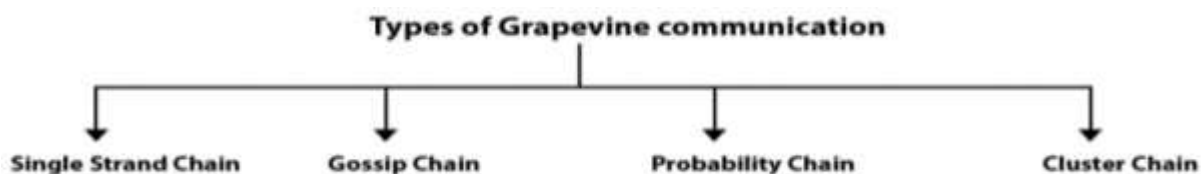

**Figure 2:** Structural flows of a grapevine communication.

**Source:** Pravin (2013)

*The Single Strand Chain-* In this structure, it flows like a chain, i.e., ‘A’ tells something to ‘B’ who tells it to ‘C’ and so on.



**Figure3:** Structural flows of a grapevine communication.

**Source:** Pravin (2013)

**The Gossip Chain-** in this chain one person tells everybody else. This chain passes a message regarding a ‘not-on-job’ nature. For Tehaeureka (2012), grapevine communication is the informal communication network within an organization which is used to spread information bypassing the formal communication structure. Just like the grapevine plant, it spreads in random ways and it goes where it can. The grapevine is formed by individuals and groups in an organization. The people in the groups have something in common that links them together. A person can belong to one or more groups.

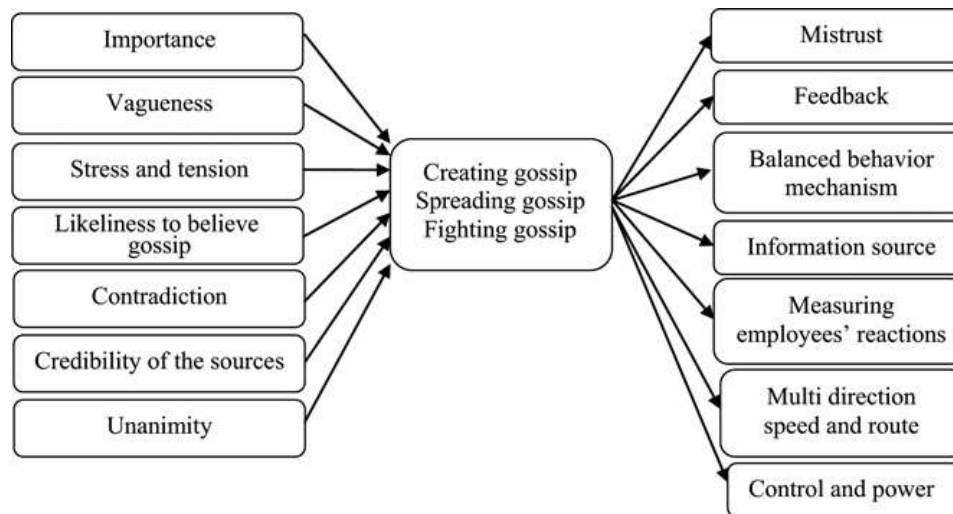

**Figure 4:** The Gossip Chain. **Source:** Tehaeureka (2012)

*The Probability Chain-* In probability chain information may move from anybody to anybody. This chain is found when the information is somewhat interesting but not really significant.

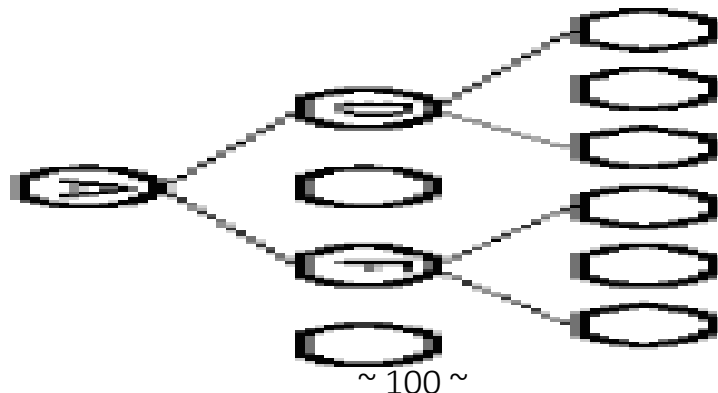

**Figure 5:** The Probability Chain

Source: Tehaeureka (2012)

**The Cluster Chain:** In cluster chain information move through selected groups. ‘A’ tells something to a few selected individuals and then some of these individuals inform a few other selected individuals. Cluster chain is the dominant grapevine pattern in an

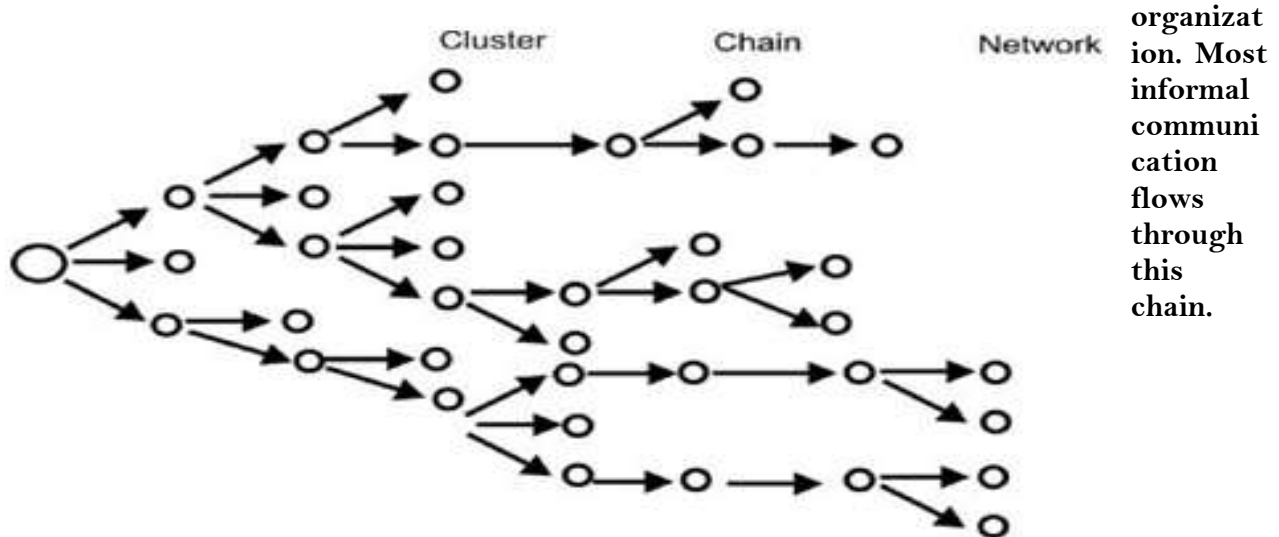

**Figure 6:** The Cluster Chain. Source: Tehaeureka (2012)

Grapevine network is commonly criticized for its widely features. The features of grapevine communication can be discussed both in positive and negative manners. We will go for that after a few moments. Grapevine has three main characteristics: it is not controlled by management; it is perceived by the most employees as being more believable and reliable; it is largely used to serve the self-interest of those people within it. Now features of grapevine can be discussed in the following manner:

**Flexibility:** There is no formal control on grapevine; or this reason, it is more flexible system than any other ways of communication.

**Lack of control:** Actually, there is no managerial control over the grapevine communication system. It is grown by itself.

**Rapid communication:** Grapevine communication system is faster than other formal or informal channels of communication.

**No record:** We can't keep any documentary record or evidence of grapevine communication system that can be shown or produced as future reference

**Used for self-interest:** As grapevine communication system is produced by gossip and rumor, it is basically used for self-interest of the employees of an organization.

**Popular among employees:** This communication system is much popular among the employees than other formal or informal channels.

**Distortion:** Distorting of real message is one of the major features of grapevine communication system. In this communication process, information passes rapidly man to man. That's why the information loses its originality.

**Spontaneous:** Grapevine is basically spontaneous. It passes rapidly and spontaneously from top to bottom of the organization. Here is no need to make any effort to make it successful.

Rumor remain a false or unascertained information that may likely not be true. Harrison (2013) underscores that rumors can be transmitted in four forms: first, the Pipe Dreams or Wish Fulfillment, which targets on identifying the wishes and hopes of employees and strive for it; second, the Bogie Rumor- it is exaggerating employees' fears and concerns in an organization; third, Wedge Drivers- this is an aggressive, unfriendly and damaging rumor which targets on split groups and dissolve allegiances; finally, the Home-Stretchers, which works on anticipating the final decisions of the managers and/or announcements with the aim of filling the gap during times of ambiguity.

Besides, the types of rumors that are spread through grapevine communication can be classified into two groups, spontaneous and premeditated (Kumar, 2013). Spontaneous rumors are spread when people are stressed or in an untrustworthy environment. Premeditated rumors spread within highly competitive environments. These two groups can be broken down into four classifications: wish fulfillment, anxiety, wedge drivers, and home stretchers. These types of rumors can also be spread through other types of informal network structures such as the single strand chain, the cluster chain, the probability chain, and the gossip chain

Rumors are the primary negative feature of the grapevine. These are based on unverified information communicated through the grapevine that lacks substantial supportive evidence. The greater the stress or importance or ambiguity in a given situation, the greater the likelihood of rumors to exist. "Rumors often start when management disastrously tries to hide things from employees" (Lussier, 2015). Rumors can take on a life of their own and threaten the organization. The activities of an organization's counterculture ranging from dissenters to actual subversives can be spread through the grapevine de-tailing reasons for these anti-management positions. Lacking a proactive organizational communication process, rumors regarding these activities can spread through the grapevine.

Rumors are powerful forms of grapevine communication because they offer explanations for events or offer hope for certain outcomes. Rumors also can reflect genuine fears held by organizational members. To minimize rumors, managers are counseled to keep employees informed, pay heed to the rumors, act promptly, and enlighten employees (Vickery, 2014). Essentially, feeding the grapevine with a great deal of valid information is the secret to making this important channel of communication productive. An entire field of study called Urban Legends relates to the wide-spread acceptance of stories that have no actual validity. Starting

with a phrase like, "It must be true, it happened to ..." these examples of modern folklore carry some type of poetic justice or moral about how to deal with certain situations.

Some managers find the grapevine useful when it passes information they like and they call it gossip and rumor when the information is unfavorable. This is a myopic view of communication. Whatever passes through the grapevine provides important information regarding the organization. In conclusion, the grapevine is important, because it reflects the quality of the activities within the organization, fills an information void, and provides meaning to organizational activities. Contrary to popular assumptions, it is fast, accurate, and oriented toward information rather than gossip. In the absence of information, rumors occur to help explain events. Combating rumors requires a proactive approach to sharing information (Kumar, 2013).

In addition to identifying certain structured patterns, research has also given us some other facts and descriptions, it has been discovered that only 10% of all the individuals in an organization are highly active participants in the grapevine. The types of individuals relative to rumors, have been identified. The three are bridgers, baggers, and bearers. Most employees fall into one of the three (3) basic categories as they relate to the grapevine (Kumar, 2012; 2013):

The messages flowing through grapevine have greater speed than that of the messages flowing through the formal channels (Harrison, 2013). The author said that the grapevine may carry equally vital message through it for the achievement and success of the organization. It is not correct to underestimate the grapevine by saying that the vital messages pass only through the authorized, formal channels. On the other hand, though the formal channels are systematic, pre-planned and documented, it is authority-laden. It can never be as speedy and spontaneous as the grapevine. The employees communicate through grapevine, not because they are compelled to communicate but because they earnestly want to communicate with their associates. The grapevine is non-expensive method and most-rapid oral method of transmitting the information to the maximum number of the communication receivers. The grapevine can flow wherever the participants wish it to flow; therefore, the manager can use the properly cultivated grapevine in dealing with the problems that require crossing the boundaries between the departments.

Grapevine originates from the psychological need of the employees to talk about their jobs and their associates as the subject of their main interest. The absence of grapevine surely creates the dull, sick and unfriendly atmosphere in the business organization. Grapevine is also described as the barometer of public opinion in the organization. If the manager is sensitive to it, he can gather information about the ideas, opinions, attitudes and interests of the employees. The grapevine gives an opportunity to the employees to let off the suppressed air of anxiety, worries and frustration. When they talk about their associates, they get emotional relief. The fact that the employees talk about their associates or that they have the interest in their associates is a proof of the high morale. Thus, the grapevine not only promotes unity, integrity and solidarity of the organization but it also helps to raise the morale of the employees.

Generally, there are three specific attributes of the grapevine that make it important and useful: it is fast, accurate, and carries a great deal of information (Goldhaber, 2013). First, the grapevine is fast. In situations involving job security or lay-offs, for example, numerous organizations have learned just how quickly the news spreads through the grapevine. Messages spread quickly as organizational members seek meaning. Second, the grapevine is surprisingly accurate; rather than being a source of unfounded gossip, the grapevine has an accuracy of 75% to 90% for noncontroversial information Lussier in Ayoro and Onyeike (2020). When errors do occur, they are generally in the area of incorrect emphasis based on incomplete information. The grapevine is not always right, of course, because being 75% to 90% accurate also means

that the grapevine is inaccurate 10% to 25% of the time. Finally, the grapevine contains a significant amount of information. In addition to the messages regarding the organization's health or the employees' sentiments, the grapevine allows organizational members to vent messages that simply do not fit into the formal channels of communication. In the same vein, grapevines can carry socially oriented messages, which develop relationships and enhance a sense of belonging. In the bargain, the formal channels of communication often require reinterpretation so that the majority of employees can understand fully the meaning of the messages, which is accomplished through the grapevine.

### **Job Performance**

Job performance as it relates to the teaching profession is an index of teachers' effectiveness which refers to the relationship between characteristics of the teachers and their effects on educational outcomes of classroom teaching (Nwosu, 2017). He revealed further that teachers' performance refers to actions or procedure a teacher embarks upon in order to attain specific school goals. Performance very much depends on perception, values and attitudes. There appear to be many variables influencing job performance are perception, values and attitude.

Teachers are expected to render a very high job performance, and the Ministry of Education is always curious regarding the job performance of its teachers. Also, the Ministry of Education demands a very high measure of loyalty, patriotism, dedication, hard work and commitment from its teachers (Ayeni, 2014). Similarly, the roles and contexts of education's motivational methods and tools cannot be underemphasized because high motivation enhances productivity which is naturally in the interests of all education.

The performance of employees on different jobs in close coordination is needed for success of the organization (Macey & Schneider, 2018). Employees are performing different jobs in an organization depending upon the nature of the organization. They mainly perform tasks like production, storage, manufacturing, transportation, marketing, purchasing, distribution, promotion of business, finance and accounting, human resource, research and public relations. All these activities are interrelated to achieve the targets. These are to be performed by the employees properly so they can give their best output at the job. This will have great impact on the total production and progress of the organization. Various factors like training, motivation, dedication, welfare, management policies, fringe benefits, salary and packages, promotion, communication etc. are responsible to encourage the people to work sincerely and give their best output (Korkaew&Suthinee, 2012). The importance of employees' performance must be understood by the management and sincere efforts must be put in that direction.

### **Methodology**

A correlational design was adopted for the study. The research area was South-South Nigeria. The population of this study was 1,644 respondents which comprises all the 17 principals and 1,627 teachers of all the seventeen (17) unity schools of 2020/2021 academic session in South-South education zone, Nigeria. Simple random sampling technique was used to select a total of 510 respondents which comprises of 50 teachers from the 10 selected unity secondary schools and 10 principals from each of the 10 selected unity secondary schools. The instruments for data collection were 'School Communication of Administrators Questionnaire (SCAQ)' and 'Teacher Job Performance Questionnaire (TJPQ)'. The data obtained were analysed

using Pearson Moment Correlation Coefficient. Linear Regression analysis (ANOVA) was used to test the null hypotheses at 0.05 level of significance.

**Result and Hypotheses**

**Research Question 1:**

To what extent do school administrators’ grapevine communication relate with teachers’ job performance of unity schools?

**Table 1: Correlation matrix on the extent of relationship between school administrators’ grapevine communication and teachers’ job performance in unity schools**

		<b>School administrators’ grapevine communication</b>	<b>Teachers job performance in unity schools</b>
<b>school administrators’ grapevine communication</b>	Pearson Correlation	1	0.65*
	N	510	510
<b>Teachers job performance in unity schools</b>	Pearson Correlation	0.65*	1
	R <sup>2</sup>	0.42(42%)	
	N	510	510

\* Correlation Significant at 0.05 level, N = Number of respondent R<sup>2</sup> coefficient of determination

Data in Table 1 reveal that there was a high extent of correlation between school administrators’ electronic communication and teachers’ job performance in unity secondary schools in SouthSouth, Nigeria as indicated by the correlation coefficient of 0.65 which is positive and within the coefficient limit of +/-0.60 to 0.79 as established by Creswell (2008). Similarly, the coefficient of determination (R<sup>2</sup>) of 0.42 indicates that 42% of the variance observed in teachers’ job performance in unity secondary schools in SouthSouth, Nigeria was accounted for by school administrators’ grapevine communication. The result is in support of the findings of Sapre, (2011) who highlighted that the effectiveness of grapevine communication channel depends on organizational climate, employee trust, and management’s ability to engage with and guide the informal network. The findings of the result is also in support of Prakashv (2019), who mentioned that grapevine is a type of internal informal communication network which is not actually sanctioned by the organization. It links employees from in direction ranging from higher authorities to least workers

**Hypothesis one**

There is no significant relationship between school administrators’ grapevine communication and teachers’ job performance in unity secondary schools in SouthSouth Nigeria.

**Table 2 : Simple Linear Regression Analysis of school administrators’ grapevine communication and teachers’ job performance in unity schools**

Model		Sum of Squares	Df	Mean Square	F	P-value
1	Regression	3067.651	1	3067.651	268.86	.021
	Residual	5807.876	509	11.410		
	Total	8875.527	510			

Df= degree of freedom, F = F-calculated, Correlation is significant at the 0.05 level (2-tailed)

The result in Table 2 shows F – calculated value of 268.86 at 0.05 level of significance. The table also shows a p -value of .021 which is less than the significant value of 0.05. Thus, null hypothesis which states that there is no significant relationship between school administrators’ grapevine communication and teachers’ job performance in unity secondary schools in South-South Nigeria is rejected. This implies that there is a significant relationship between school administrators’ grapevine communication and teachers’ job performance in unity secondary schools in South-South Nigeria. The result is in support of the findings of Bratton et al. (2017) who explained that grapevine communication is built on cordial relationships among staff and may exist alongside formal communication structures. Although grapevine communication is sometimes criticized for spreading rumors or distorted information, it can also serve useful purposes by helping employees share ideas, clarify issues, and understand organizational activities. The result is also in support of Greenberg & Baron, (2018) who highlighted that when school administrators use the grapevine effectively, they can provide timely updates, clarify expectations, and engage teachers in meaningful conversations that enhance understanding and motivation

**CONCLUSION**

The study examined school administrators’ grapevine communication and teachers’ job performance in unity secondary schools in South-South, Nigeria. Based on the findings of the study, there was a high and significant relationship between school administrators’ grapevine communication and teachers’ job performance in unity secondary schools. In conclusion, the findings revealed that school administrators’ grapevine communication to a high extent relates to teachers’ job performance in unity secondary schools. This implies that effective management and use of grapevine communication by school administrators can enhance teachers’ job performance in unity secondary schools in South-South, Nigeria

**RECOMMENDATIONS**

Based on the findings and conclusions of the study, the following recommendations were made.

1. School administrators should properly manage grapevine communication in the school by providing accurate and timely information to teachers so as to reduce rumors and misinformation

2. Teachers should encourage positive use of grapevine communication by sharing useful and constructive information that can promote cooperation, teamwork, and improved job performance in the school.
3. School administrators and teachers should maintain open and honest communication so that the grapevine can serve as a supportive channel for information sharing rather than a medium for spreading false or misleading information.

**REFERENCES**

- Ayoro, R. A., & Onyeike, V. C. (2020). Principals' verbal communication skills and motivation as correlates of teachers' productivity in mission secondary schools in Delta State. *International Journal of Innovative Psychology & Social Development*, 8(1), 58–64.
- Bratton, J. M., Callinan, C., Forshaw, P., & Sawchuk, M. (2017). *Work and organizational behaviour: Understanding the workplace* (2nd ed.). Palgrave Macmillan.
- Goldhaber, P. (2013). *Multivariate data analysis* (7th ed.). Prentice-Hall.
- Greenberg, J., & Baron, R. A. (2018). *Behavior in organizations* (9th ed.). Pearson Education.
- Harrison, K. (2013). How to deal with rumors in the grapevine. *StudyMode*. Retrieved from <http://www.studymode.com/essays/Article-For-Grapevine-1565518.html>
- Ibiam, N. (2015). *Educational administration principles and practice*. Cel-Bez Publishing Co. Ltd.
- Korkaew, J., & Suthinee, R. (2012). Factors affecting job performance: A review of literature. *Silpakorn University Journal of Social Sciences, Humanities and Arts*, 12(2), 115–127.
- Kumar, R. (2012). *Basic business communication*. Excel Books India.
- Kumar, S. (2013). Grapevine communication (informal business communication). Retrieved from <http://www.scribd.com/doc/45125436/Grapevine-Communication>
- Laud, L. (2018). Changing the way we communicate. *Educational Leadership*, 55(7), 23–25.
- Lussier, M. (2015). *Teacher evaluation: A study of effective practices*. Sage.
- Macey, W. H., & Schneider, B. (2008). The meaning of employee engagement. *Industrial and Organizational Psychology*, 1(1), 3–30. <https://doi.org/10.1111/j.1754-9434.2007.00002.x>
- Nwosu, J. C. (2017). Principals' communication strategies and teachers' job performance in public secondary schools in Ikenne Local Government Area of Ogun State. *International Journal of Education, Learning and Development*, 5(9), 1–12.
- Prakashv, V. (2019). Company grapevine. *StudyMode*. Retrieved from <http://www.studymode.com/essays/Company-Grapevine-227925.html>
- Pravin, G. K. (2013). Types of communication. Retrieved from <http://pravinxk.hubpages.com/hub/Types-of-Communication>
- Sapre, O. (2011). How to handle grapevine in office. *Economic Times*. Retrieved from <http://articles.economictimes.indiatimes.com>

Sostek, A. (2016). Studies show a bit of office talk can boost productivity. *Pittsburgh Post-Gazette*. Retrieved from <https://www.post-gazette.com/>

Tehaeureka, N. F. S. (2012). Gossip and grapevine. *StudyMode*. Retrieved from <http://www.studymode.com/essays/Gossip-And-Grapevine-1017255.html>

Tubbs, S., & Moss, S. (2008). *Human communication: Principles and contexts* (11th ed.). McGraw-Hill Higher Education.

Vickery, D. E. (2016). Verbal communication behaviors of principals at high performing Title I elementary schools in Virginia. *Creighton Journal of Interdisciplinary Leadership*, 2(2), 2–16.

Wentz, P. (2018). Successful communications for school leaders. *NASSP Bulletin*, 82(601), 112–115.